

CHART A

Torch Model	Amps	Nozzle	Length (A)
WT-22A,B WT-23A,B	260	Standard Nozzle	1 5/16"
		Long Nozzle 1 7/8"	2 1/16"
		Extra Long Nozzle 2 1/2"	2 13/16"
	130	Gas Lens Nozzle	1 3/16"
		Medium Dia. Gas Lens Nozzle	1 7/16"
		Large Dia. Gas Lens Nozzle	2 1/16"
WT-28A,B WT-29A,B	350	Standard Nozzle	2 3/16"
		Long Nozzle 3"	3 5/16"
	180	Gas Lens Nozzle	2 1/4"
		Large Dia. Gas Lens Nozzle	2 3/8"

SPECIFICATIONS

Torch Model	Maximum Amps (ac-dcsp)	Duty Cycle (ac-dcsp)	Tungsten Capacity	Max. Length	Cooling Requirements
WT-22A WT-22B	260	60%	.020 - 1/8	7" 14"	Water Cooled 1 Qt./min. (50 psi MAX. OUTPUT)
WT-23A WT-23B	130	60%	.020 - 3/32	7" 14"	Air Cooled
WT-28A WT-28B	350	60%	.020 - 5/32	7" 14"	Water Cooled 1 Qt./min. (50 psi MAX. OUTPUT)
WT-29A WT-29B	180	60%	.020 - 1/8	7" 14"	Air Cooled

COPYRIGHT 2000 - 2019 TEC WELDING PRODUCTS, INC.

Note: Specifications and dimensions are subject to change without notice.

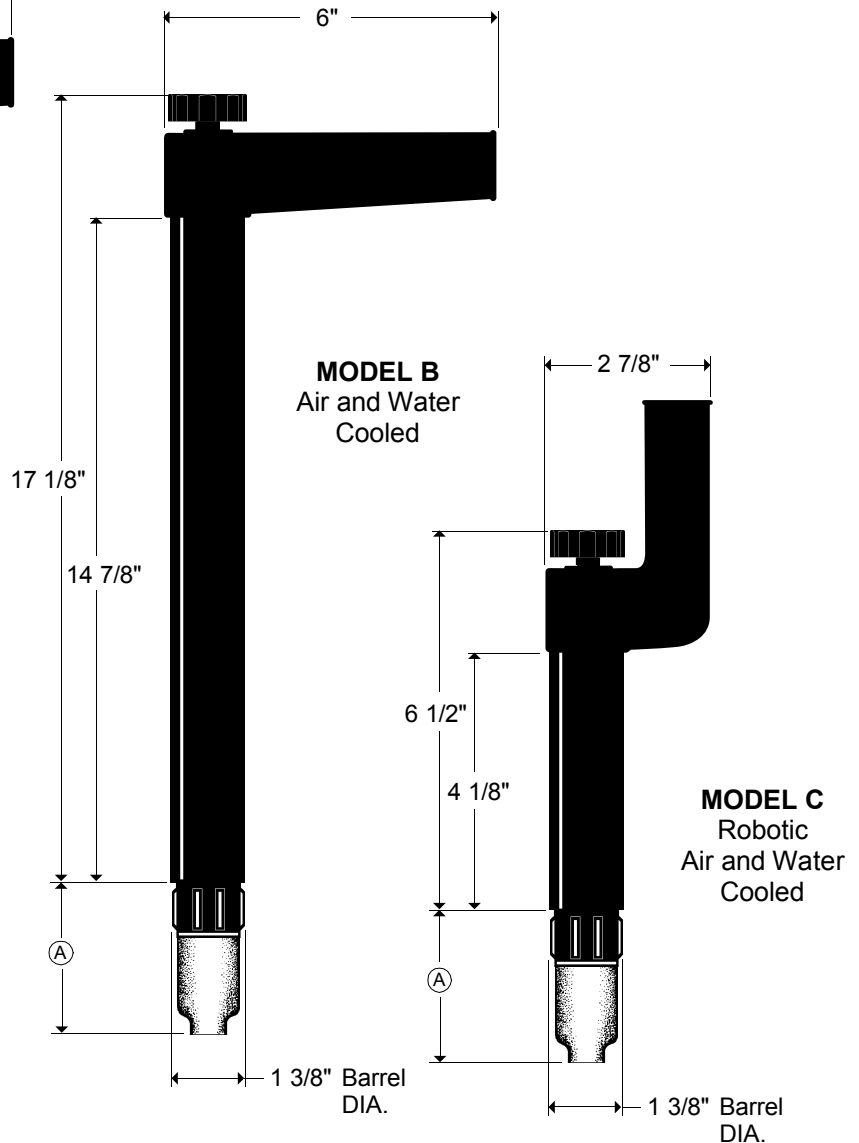
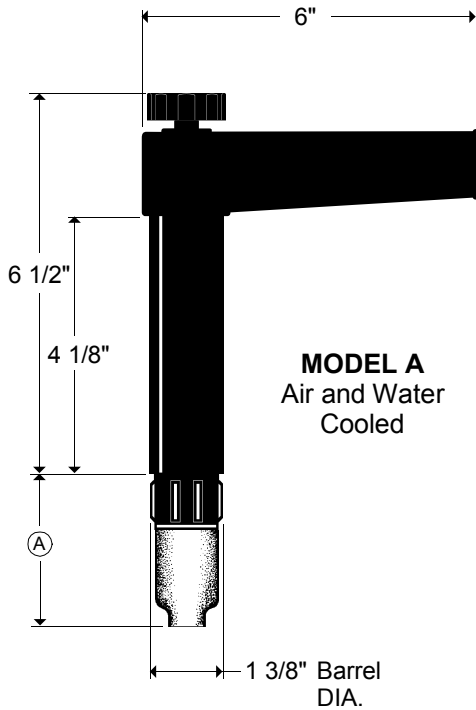

CHART A

Torch Model	Amps	Nozzle	Length (A)
WT-27AA WT-27BA WT-27CA	200	Standard Nozzle	2 3/4"
		Long Nozzle 2 3/4"	3 5/8"
		Extra Long Nozzle 3 1/4"	4 1/8"
WT-27AW WT-27BW WT-27CW	500	Extra Extra Long Nozzle 4 3/4"	5 5/8"
		Metal Nozzle	3"

SPECIFICATIONS

Torch Model	Maximum Amps (ac-dcsp)	Duty Cycle (ac-dcsp)	*Tungsten Capacity	Max. Length	Cooling Requirements
WT-27AA WT-27BA WT-27CA	200	60%	.040 - 1/4	7" 18" 7"	Air Cooled
WT-27AW WT-27BW WT-27CW	500	60%	.040 - 1/4	7" 18" 7"	Water Cooled 2 Qt./min. (50 psi MAX. OUTPUT)

* Axial adjustment of tungsten electrode is possible by moving the ribbed sleeve and shaft knob in unison.